

LANCIA

DEDRA (835)

1,6ie/1616V/1,6LE/1,8ie/1,816V1,8GT
2,0ie/2016V/2,0HF/ 1,9TDS

Ltr. 1,6/1,8/2,0
1,9TDS









Baujahr
Year 01/1989 - 07/1999

DEDRA SW (835) (KOMBI)

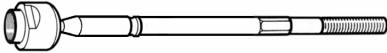
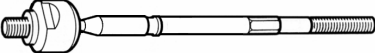
1,6ie/1616V/1,8ie/1,816V1,8GT2,016V/2,0Integ.
1,9TDS

1,6/1,8/2,0
1,9TDS

07/1994 - 07/1999

VERGLEICHS-NR. CROSS-REF.-NO.	HEYD-NR.	BENENNUNG / ABMESSUNG DESCRIPTION / DIMENSION	EINBAU POSITION	BILD FIGURE
60 809 495 7591 216	FT 14.71	Spurstangengel. Innengew. Tie rod end, internal thread M12x1,5 RH	L ⇐	
60 809 494 7591 215	FT 14.72	Spurstangengel. Innengew. Tie rod end, internal thread M12x1,5 RH	R ⇒	
<i>MANUELLE LENKUNG / MANUAL STEERING</i>				
7633 721	FT 13.75	Axialgelenk Axial joint M12X1,5 RH	L+R ⇒ ⇐	
<i>SERVOLENKUNG / POWER STEERING</i>				
9941 625	FT 13.74	Axialgelenk Axial joint M12X1,5 RH	L+R ⇒ ⇐	
<i>BIS/UP TO MOD.> 6/ 1990</i>				
7601 0372 760 1057	FT 14.83	Querlenker mit Gummilager Control arm with bushing Ø15mm	L ↓	
7601 0373 760 1062	FT 14.82	Querlenker mit Gummilager Control arm with bushing Ø15mm	R ↓	
<i>AB/ FROM MOD.7/ 1990 ></i>				
8246 1081 4642 3822 777 7239	FT 14.85	Querlenker mit Gummilager Control arm with bushing Ø17mm	L ↓	
8246 1082 4642 3823 777 7240	FT 14.84	Querlenker mit Gummilager Control arm with bushing Ø17mm	R ↓	
6080 9242	FT 14.41	Pendelstütze Vorderachse Self-alignment link front axle	L+R ↗↘ 	

LANCIA

DELTA I (831 ABO)

1,3/1,5/1,6GT/1,6HF/1,8S4/2,0HF/2,016VHF
1,9TurboDS

Ltr. 1,1/1,3/1,5/1,6/1,8/2,0
1,9D



Baujahr 09/1979 - 01/1994
Year

PRISMA (831 ABO)

1,5/1,6/1,6ie/2,0ie4x4
1,9D/1,9TurboD

1,3/1,5/1,6/2,0
1,9D

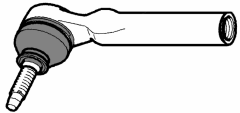
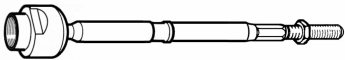
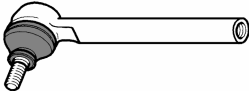
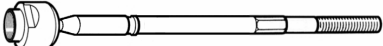
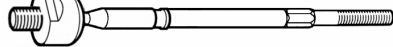
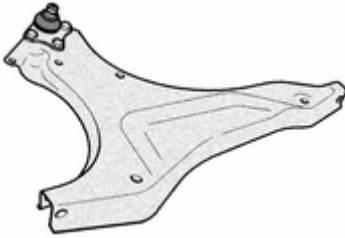
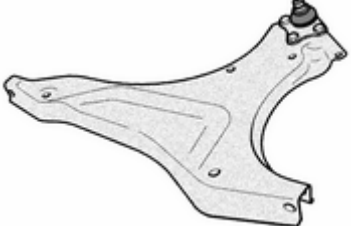



01/1983 - 02/1992

VERGLEICH-NR. CROSS-REF.-NO.	HEYD-NR.	BENENNUNG / ABMESSUNG DESCRIPTION / DIMENSION	EINBAU POSITION	BILD FIGURE
8235 1945	LA 01.74	Spurstangengel. Innengew. Tie rod end, internal thread M14x1,5 RH	L+R ⇐⇒	
8235 5565	LA 01.75	Axialgelenk Axial joint M14X1,5 RH	L+R ⇐ ⇐	
<i>AB/FROM MOD. 1985</i>				
754 5270	LA 01.76	Spurstangengel. Innengew. Tie rod end, internal thread M12x1,5 RH	L+R ⇐⇒	
<i>MANUELLE LENKUNG / MANUAL STEERING</i>				
763 3721	FT 13.75	Axialgelenk Axial joint M12X1,5 RH	L+R ⇐ ⇐	
<i>SERVOLENKUNG / POWER STEERING</i>				
993 9038	FT 01.78	Axialgelenk Axial joint M12X1,5 RH	L+R ⇐ ⇐	
8237 0203	FT 01.81	Querlenker ohne Gummilager Control arm without bushing	L ↓	
8237 0204	FT 01.80	Querlenker ohne Gummilager Control arm without bushing	R ↓	
8234 6006	LA 01.91	Traggelenk Vorderachse Suspension joint, front axle	L+R ↓	

DELTA II (836)
1,4ie/1,6ie/1,8/1,8ie/2,016V
1,9TD

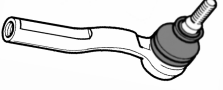
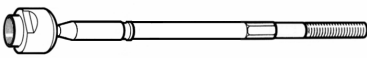
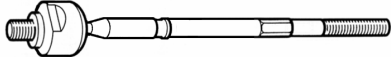
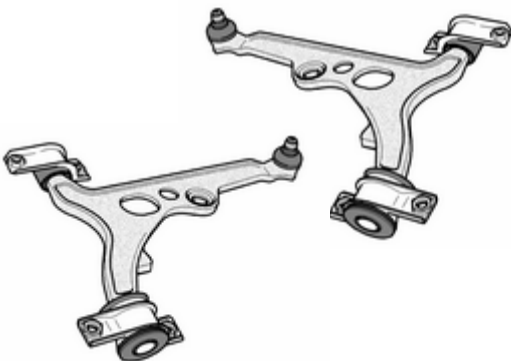
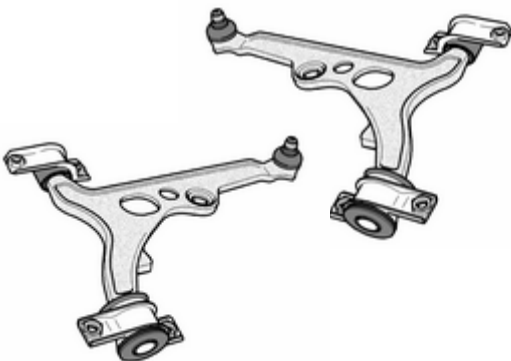
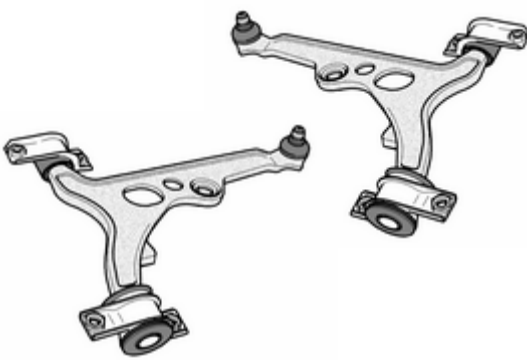
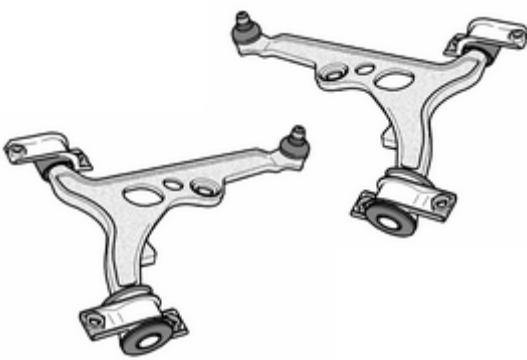
Ltr. 1,4/1,6/1,8/2,0
1,9TD

Baujahr 06/1993 - 08/1999
Year

VERGLEICHS-NR. CROSS-REF.-NO.	HEYD-NR.	BENENNUNG / ABMESSUNG DESCRIPTION / DIMENSION	EINBAU POSITION	BILD FIGURE
60 809 495 7591 216	FT 14.71	Spurstangengel. Innengew. Tie rod end, internal thread M12x1,5 RH	L ⇐	
60 809 494 7591 215	FT 14.72	Spurstangengel. Innengew. Tie rod end, internal thread M12x1,5 RH	R ⇐	
<i>MANUELLE LENKUNG / MANUAL STEERING</i>				
763 3721	FT 13.75	Axialgelenk Axial joint M12X1,5 RH	L+R ⇐ ⇐	
<i>SERVOLENKUNG / POWER STEERING</i>				
994 1625	FT 13.74	Axialgelenk Axial joint M12X1,5 RH	L+R ⇐ ⇐	
8246 1081 4642 3822 777 7239	FT 14.85	Querlenker mit Gummilager Control arm with bushing Ø17mm	L ↓	
8246 1082 4642 3823 777 7240	FT 14.84	Querlenker mit Gummilager Control arm with bushing Ø17mm	R ↓	
<i>1,6HPE/1,8/2,0/1,9TD</i>				
6081 1769 46 474 556	FT 14.89	Querlenker mit Gummilager Control arm with bushing	L ↓	
6081 1770 46 474 557	FT 14.88	Querlenker mit Gummilager Control arm with bushing	R ↓	
8244 6499 8239 8170	FT 05.95	Traggelenk Vorderachse Suspension joint, front axle	L+R ↓	
6080 9242	FT 14.41	Pendelstütze Vorderachse Self-alignment link front axle	L+R ↗ ↘ 	

LANCIA

KAPPA (838A)

2,016V/2,020V/2,420V/3,024V
2,4JTD/2,4TDS

Ltr. 2,0/2,4/3,0
2,4

Baujahr **08/1994 - 10/2001**
Year

KAPPA SW (838B) (KOMBI)

2,016V/2,020V/2,420V/3,024V
2,4JTD/2,4TDS

2,0/2,4/3,0
2,4D



07/1996 - 10/2001

KAPPA COUPE (838)

2,016V/2,020V/2,420V/3,024V

2,0/2,4/3,0

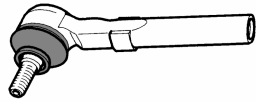
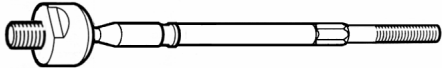
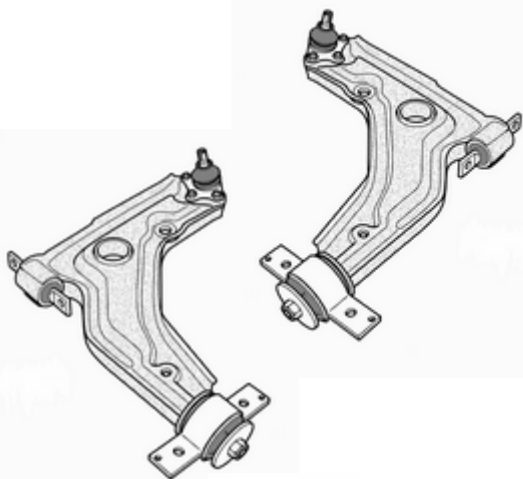
07/1996 - 03/2001

VERGLEICHS-NR. CROSS-REF.-NO.	HEYD-NR.	BENENNUNG / ABMESSUNG DESCRIPTION / DIMENSION	EINBAU POSITION	BILD FIGURE
8246 0439	FT 05.72	Spurstangengel. Innengew. Tie rod end, internal thread M14x1,5 RH	L+R ⇔	
994 5565	LA 02.74	Axialgelenk Axial joint M14X1,5 RH	L+R ⇔ ⇔	
4641 4734	LA 02.81	Querlenker mit Gummilager Control arm with bushing	L ↓	
4641 4735	LA 02.80	Querlenker mit Gummilager Control arm with bushing	R ↓	
8248 0099	LA 02.91	Traggelenk Vorderachse Suspension joint, front axle	L+R ↓	

LANCIA

LYBRA (839AX)

1,616V/1816V/2,020V
1,9JTD/2,4JTD

Ltr. 1,6/1,8/2,0
1,9D/2,4D

Baujahr **07/1999 -**
Year

LYBRA SW (839BX) (KOMBI)

1,616V/1816V/2,020V
1,9JTD/2,4JTD

1,6/1,8/2,0
1,9D/2,4D

07/1999 -

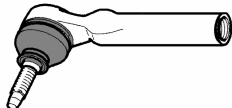
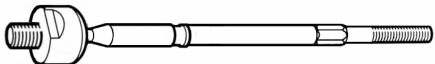
VERGLEICHS-NR. CROSS-REF.-NO.	HEYD-NR.	BENENNUNG / ABMESSUNG DESCRIPTION / DIMENSION	EINBAU POSITION	BILD FIGURE
994 7926	LA 06.01	Spurstangengel. Innengew. Tie rod end, internal thread M12x1,5 RH	L+R ⇔	
994 8296	LA 06.03	Axialgelenk Axial joint M12X1,5 RH	L+R ⇔ ⇔	

FORTSETZUNG / CONTINUATION

LANCIA

LYBRA (839AX)
1,616V/1816V/2,020V
1,9JTD/2,4JTD



Ltr. 1,6/1,8/2,0
1,9D/2,4D

Baujahr **07/1999** -
Year

LYBRA SW (839BX) (KOMBI)
1,616V/1816V/2,020V
1,9JTD/2,4JTD

1,6/1,8/2,0
1,9D/2,4D

07/1999 -

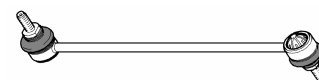

VERGLEICHS-NR. CROSS-REF.-NO.	HEYD-NR.	BENENNUNG / ABMESSUNG DESCRIPTION / DIMENSION	EINBAU POSITION	BILD FIGURE
4652 5407	FT 06.81	Querlenker mit Gummilager Control arm with bushing	L ↓	
4652 2142	FT 06.80	Querlenker mit Gummilager Control arm with bushing	R ↓	
4654 5743	LA 06.41	Pendelstütze Vorderachse Self-alignment link front axle	L+R 	

LANCIA

MUSA (GROSSRAUMLIMOUSINE)
1,4
1,3Multijet/1,9Multijet

Ltr. 1,4
1,3D/1,9D

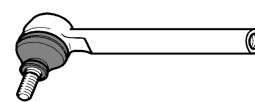
Baujahr **10/2004** -
Year

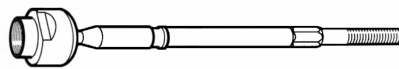
VERGLEICHS-NR. CROSS-REF.-NO.	HEYD-NR.	BENENNUNG / ABMESSUNG DESCRIPTION / DIMENSION	EINBAU POSITION	BILD FIGURE
7736 2503	FT 04.18	Spurstangengel. Innengew. Tie rod end, internal thread M14x1,5 RH	L+R 	
7736 2502	FT 04.19	Axialgelenk Axial joint M14X1,5 RH	L+R 	

LANCIA

MUSA (GROSSRAUMLIMOUSINE)

1,4
1,3Multijet/1,9Multijet

Ltr. 1,4
1,3D/1,9D

Baujahr 10/2004 -
Year

VERGLEICHS-NR. CROSS-REF.-NO.	HEYD-NR.	BENENNUNG / ABMESSUNG DESCRIPTION / DIMENSION	EINBAU POSITION	BILD FIGURE
5070 3232	FT 04.89	Querlenker mit Gummilager Control arm with bushing	L ↓	
5070 3231	FT 04.88	Querlenker mit Gummilager Control arm with bushing	R ↓	

LANCIA

PHEDRA (179) (GROSSRAUMLIMOUSINE)

2,0/3,0V6
2,0JTD/2,0D Multijet/2,2JTD

Ltr. 2,0/3,0
2,0D/2,2D

Baujahr 09/2002 -
Year

VERGLEICHS-NR. CROSS-REF.-NO.	HEYD-NR.	BENENNUNG / ABMESSUNG DESCRIPTION / DIMENSION	EINBAU POSITION	BILD FIGURE
7736 2279 4059.12	CT 03.14	Spurstangengel. Innengew. Tie rod end, internal thread M14x1,5 RH	L+R ⇔	
7736 2280 3812.E2	CT 03.15	Axialgelenk Axial joint M14X1,5 RH	L+R ⇔ ⇔	
9350 1487 3521.H0	CT 03.85	Querlenker mit Gummilager Control arm with bushing	L ↓	
9350 1488 3521.H1	CT 03.84	Querlenker mit Gummilager Control arm with bushing	R ↓	
1331 209 080 5087.51	CT 03.43	Pendelstütze Vorderachse Self-alignment link front axle	L+R ↗↘ 	

LANCIA

THEMA (834)

2000ie/2000ie16V/2000ieTurbo/200016V/
200016VTurbo/2850V6ie/8,32/3000V6
2500TurboD/2500TurboDS

Ltr. 2,0/2,8/2,9/3,0
2,4D/2,5D



Baujahr 11/1984 - 07/1994
Year

THEMA SW (834) (KOMBI)

2000ie16V/2000Turbo/200016V/2000ieTurbo/
2000Turbo16V/3000V6
2500TurboDS

2,0/3,0
2,5D

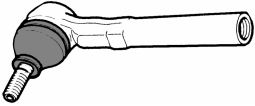
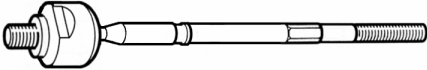
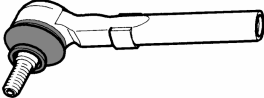
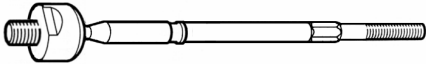
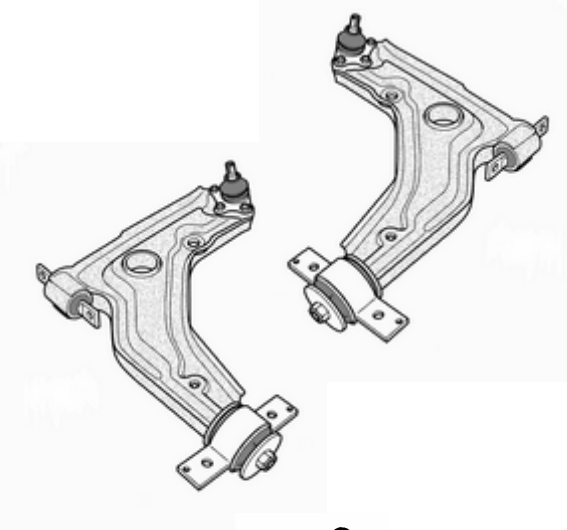
03/1987 - 07/1994









VERGLEICHS-NR. CROSS-REF.-NO.	HEYD-NR.	BENENNUNG / ABMESSUNG DESCRIPTION / DIMENSION	EINBAU POSITION	BILD FIGURE
<i>BIS/UP TO MOD.> 3/ 1986</i>				
993 9556	FT 05.73	Spurstangengel. Innengew. Tie rod end, internal thread M12x1,5 RH	L+R ⇔⇔	
993 9557	FT 05.74	Axialgelenk Axial joint M12X1,5 RH	L+R ⇔ ⇔	
<i>AB/FROM MOD. 4/ 1986></i>				
994 1186	LA 02.71	Spurstangengel. Innengew. Tie rod end, internal thread M14x1,5 RH	L+R ⇔⇔	
994 5585 994 0260	LA 02.72	Axialgelenk Axial joint M14X1,5 RH	L+R ⇔ ⇔	
8240 6867	FT 05.81	Querlenker mit Gummilager Control arm with bushing	L ↓	
8240 6868	FT 05.80	Querlenker mit Gummilager Control arm with bushing	R ↓	
8244 6499 8239 8170	FT 05.95	Traggelenk Vorderachse Suspension joint, front axle	L+R ↓	

LANCIA

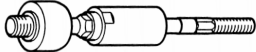
THESIS (841AX)
2,0Turbo/2,4/3,0V6/3,2V6
2,4JTD/2,4 Multijet

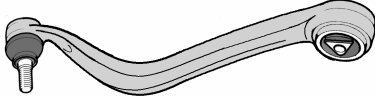
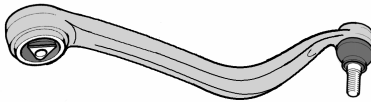
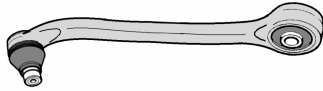
Ltr. 2,0/2,4/3,0/3,2
2,4D

Baujahr 07/2002 -
Year

VERGLEICHS-NR. CROSS-REF.-NO.	HEYD-NR.	BENENNUNG / ABMESSUNG DESCRIPTION / DIMENSION	EINBAU POSITION	BILD FIGURE
9 947 919	AF 06.01	Spurstangengel. Innengew. Tie rod end, internal thread M14x1,5 RH	L ⇨	
9 947 920	AF 06.02	Spurstangengel. Innengew. Tie rod end, internal thread M14x1,5 RH	R ⇧	
9 949 311	LA 06.05	Axialgelenk Axial joint M14X1,5 RH	L+R ⇨ ⇧	
60 678 239	LA 06.81	Querlenker mit Gummilager Control arm with bushing Vorderachse / front axle	L ↑	
60 678 238	LA 06.80	Querlenker mit Gummilager Control arm with bushing Vorderachse / front axle	R ↑	
60 680 200	LA 06.83	Querlenker mit Gummilager Control arm with bushing Vorderachse / front axle	L ↓	
60 680 201	LA 06.82	Querlenker mit Gummilager Control arm with bushing Vorderachse / front axle	R ↓	
60 678 241	LA 06.84	Querlenker mit Gummilager Control arm with bushing Vorderachse / front axle	L+R ↓	
60 671 724	LA 06.43	Pendelstütze Vorderachse Self-alignment link front axle	L ↻ 	
60 671 725	LA 06.42	Pendelstütze Vorderachse Self-alignment link front axle	R ↻ 	

LANCIA

Y10 (156)

1,0Fire/1,0Fire 4WD/1,0Turbo/1,1ie/1,1ie 4WD
1,1ieFire/1,1ieFire 4WD/1,1Avenue/1,1Avenue 4WD

Ltr. 1,0/1,1

Baujahr 03/1985 - 12/1995
Year

VERGLEICHS-NR. CROSS-REF.-NO.	HEYD-NR.	BENENNUNG / ABMESSUNG DESCRIPTION / DIMENSION	EINBAU POSITION	BILD FIGURE
598 3406 595 8246	FT 01.76	Spurstangengel. Innengew. Tie rod end, internal thread M12x1,5 RH	L+R ⇔⇔	
596 0321	FT 02.73	Axialgelenk Axial joint M12X1,5	L+R ⇔ ⇔	
599 5503 440 8138		Querlenker ohne Gummilager Control arm without bushing	L+R ↓	
440 2649	FT 02.91	Traggelenk Vorderachse Suspension joint, front axle	L+R ↓	
760 1261 440 2672	FT 02.92	Querlenker ohne Gummilager Control arm without bushing	L+R ↓	

LANCIA

Y (840A)

1,1/1,2/1,216V/1,412V

Ltr. 1,1/1,2/1,4

Baujahr 09/1995 - 09/2003
Year



VERGLEICHS-NR. CROSS-REF.-NO.	HEYD-NR.	BENENNUNG / ABMESSUNG DESCRIPTION / DIMENSION	EINBAU POSITION	BILD FIGURE
994 6949	FT 03.70	Spurstangengel. Innengew. Tie rod end, internal thread M12x1,5 RH	L+R ⇔⇔	
994 5562	FT 03.74	Axialgelenk Axial joint M12X1,5 RH	L+R ⇔ ⇔	
4643 0003	FT 03.80	Querlenker mit Gummilager Control arm with bushing	L ↓	
4643 0002	FT 03.81	Querlenker mit Gummilager Control arm with bushing	R ↓	

LANCIA

YPSILON
1,2/1,4
1,3JTD/1,3 Multijet

Ltr. 1,2/1,4
1,3D

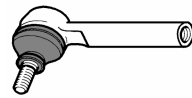
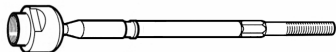
Baujahr 10/2003 -
Year

VERGLEICHS-NR. CROSS-REF.-NO.	HEYD-NR.	BENENNUNG / ABMESSUNG DESCRIPTION / DIMENSION	EINBAU POSITION	BILD FIGURE
7736 2381	LA 04.10.	Spurstangengel. Innengew. Tie rod end, internal thread M12x1,5 RH	L+R ⇔⇔	
7736 2380	LA 04.11	Axialgelenk Axial joint M12X1,5 RH	L+R ⇔ ⇔	
5070 3232	FT 04.89	Querlenker mit Gummilager Control arm with bushing	L ↓	
5070 3231	FT 04.88	Querlenker mit Gummilager Control arm with bushing	R ↓	

LANCIA

ZETA (220) (GROSSRAUMLIMOUSINE)
2,016V/2,0Turbo
2,0JTD/2,1TD

Ltr. 2,0
2,0D/2,D

Baujahr 05/1995 - 09/2002
Year

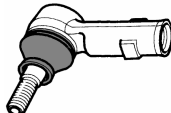
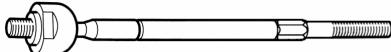

VERGLEICHS-NR. CROSS-REF.-NO.	HEYD-NR.	BENENNUNG / ABMESSUNG DESCRIPTION / DIMENSION	EINBAU POSITION	BILD FIGURE
94 040 590 80	FT 15.73	Spurstangengel. Innengew. Tie rod end, internal thread M14x1,5 RH	L+R ⇔⇔	
95 669 508 80	FT 15.74	Axialgelenk Axial joint M14X1,5 RH	L+R ⇔ ⇔	

LANCIA

ZETA (220) (GROSSRAUMLIMOUSINE)
 2,016V/2,0Turbo
 2,0JTD/2,1TD

Ltr. 2,0
 2,0D/2,D

Baujahr 05/1995 - 09/2002
 Year

VERGLEICHS-NR. CROSS-REF.-NO.	HEYD-NR.	BENENNUNG / ABMESSUNG DESCRIPTION / DIMENSION	EINBAU POSITION	BILD FIGURE
13 226 630 80	FT 15.81	Querlenker mit Gummilager Control arm with bushing Stahl/Steel	L ↓	
13 226 640 80	FT 15.80	Querlenker mit Gummilager Control arm with bushing Stahl/Steel	R ↓	
13 174 250 80 13 086 640 80 5087.35	PE 05.42	Koppelstange, Vorderachse Stabilizer link, front axle	L+R 